

# Instructions



**ELECTRIC, VISCOUNT® II HYDRAULIC,  
240 Volt, 1 or 3 Phase, 50/60 Hz**

## **FOAM-CAT® 400 SPRAYER** 307541J

**For use only with two component urethane fluids that are unfilled and non-flammable.**

*1500 psi (105 bar) Maximum Working Pressure*



**Read warnings and instructions.**  
See page 3 for warnings.

### **Model 226992** Includes:

- Foam-Cat Heater and Heated Hose Controls
- Viscount II Hydraulic Pump
- Pump Stand
- 50 ft. (15 m), 3/8 in. I.D. Heated Hose
- 15 ft. (4.6 m), 1/4 in. I.D. Heated Whip Hose
- Spray Gun with 0.114 in. (2.9 mm) Diameter Nozzle Kit

### **Model 226994** Includes:

- Model 226992 Sprayer
- Hydraulic Power Supply
- 10 feet (3.1 m) Hydraulic Supply and Return Hoses
- 10 gallons (19 liters) Hydraulic Oil

### **Delivery**

30 lb/min at 48° F temperature rise  
(13.5 kg/min at 27° C temperature rise)

### **Power Requirements**

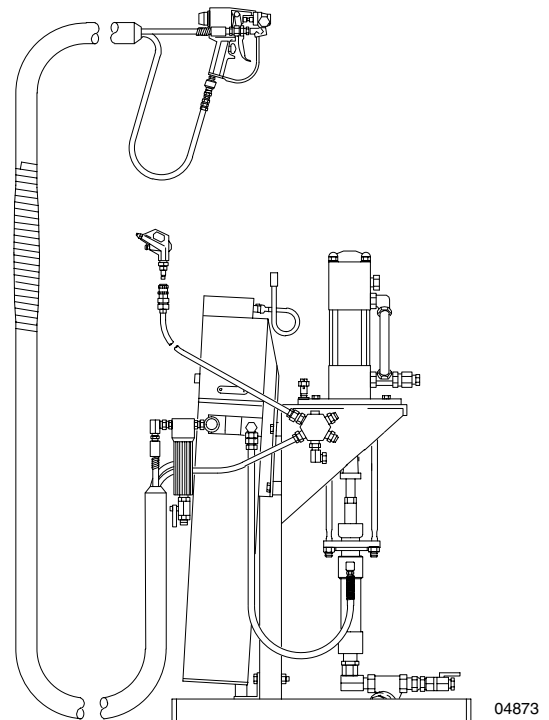
Electrical: 240 Volt Maximum  
208 Volt Minimum  
Single phase: 80 Amps  
Three phase: 60 Amps

Generator (optional): See Heater Manual, 308219 for size.

Compressed Air: 80–100 psi (5.6–6.9 bar)  
10 CFM (0.28 m<sup>3</sup>/min)

### **Certification**

The heater and heated hoses are CSA certified when used as instructed in the heater or heated hose manuals, 308219 and 307544, respectively.



**PROVEN QUALITY. LEADING TECHNOLOGY.**



# Table of Contents

<b>Symbols</b> .....	3	<b>Operation - First Time Startup</b> .....	14
<b>Warnings</b> .....	3	Pressure Relief Procedure .....	14
<b>Introduction</b> .....	6	I . Prime the hydraulic system. ....	14
Before you use this equipment .....	6	II . Prime the sprayer. ....	15
Terms .....	6	III . Adjust the air dryer. ....	15
If you are using a generator to power your system .....	6	IV . Prime the hoses. ....	16
Component manuals and recommended accessory manuals .....	6	V . Check each fluid connection for leaking. ...	16
<b>Installation</b> .....	7	<b>Operation - General Startup Instructions</b> .....	17
The Typical Installation .....	7	Start the sprayer. ....	17
Reference letters and numbers .....	7	Shutdown .....	19
I . Mount the system .....	8	Maintenance .....	19
II . Connect the air hose .....	9	<b>Parts</b> .....	20
III . Connect the heated hose assembly .....	9	<b>Graco Standard Warranty</b> .....	22
IV . Install a needle/nozzle kit on the gun .....	9	<b>Graco Information</b> .....	22
V . Connect the fluid hoses to the spray gun manifold .....	11		
VI . Connect the feed hose to the displacement pumps .....	11		
VII . Position the ATC Sensor .....	11		
VIII . Wire and electrically ground the system ...	12		
IX . Install the air dryer drum fittings .....	13		

# Symbols

## Warning Symbol



This symbol alerts you to the possibility of serious injury or death if you do not follow the instructions.

## Caution Symbol



This symbol alerts you to the possibility of damage to or destruction of equipment if you do not follow the instructions.

## WARNING



### INJECTION HAZARD

Spray from the gun, hose leaks, or ruptured components can inject fluid into your body and cause extremely serious injury, including the need for amputation. Splashing fluid in the eyes or on the skin can also cause serious injury.

- Fluid injected into the skin might look like just a cut, but it is a serious injury. **Get immediate medical attention.**
- Do not point the spray gun at anyone or at any part of the body.
- Do not put your hand or fingers over the spray tip/nozzle.
- Do not stop or deflect leaks with your hand, body, glove or rag.
- Do not “blow back” fluid; this is not an air spray system.
- Always have the trigger guard on the spray gun when spraying.
- Be sure the gun trigger safety operates before spraying.
- Lock the gun trigger safety when you stop spraying.
- Follow the **Pressure Relief Procedure** on page 14 whenever you: are instructed to relieve pressure; stop spraying; clean, check, or service the equipment; and install or clean the spray tip/nozzle.
- Tighten all fluid connections before operating the equipment.
- Check the hoses, tubes, and couplings daily. Do not mend or repair any part of the hose assembly. If the hose is damaged, replace it immediately.



### MOVING PARTS HAZARD

Moving parts, such as the motor piston can pinch or amputate fingers.

- Do not operate the equipment with the motor plates removed.
- Keep your body and tools clear of any moving parts when starting or operating the equipment.

# WARNING



## FIRE, EXPLOSION, AND ELECTRIC SHOCK HAZARD

Improper grounding, poor ventilation, open flames, or sparks can cause a hazardous condition and result in fire, explosion, electric shock or other serious injury.

- Ground the equipment and the object being sprayed. See **Wire and electrically ground the system** on page 12.
- Do not use the heater with flammable liquids, such as those having flash points below 200° F (93° C).
- All electrical wiring must be done by trained and qualified personnel and comply with all local codes and regulations.
- Do not wrap the heat tape around the hoses. Follow all hose assembly instructions to prevent strain on the heat tape.
- Do not expose the heater to rain.
- Do not operate the heater with any covers removed.
- Shut off the heater and heated hose circuit breakers before installing, checking, or repairing any part of the heater or heated hoses.
- Provide fresh air ventilation to avoid the buildup of flammable fumes from solvents or the fluid being sprayed.
- Extinguish all the open flames or pilot lights within the spray area.
- Electrically disconnect all the equipment within the spray area.
- Keep the spray area free of debris, including solvent, rags, and gasoline.
- Do not turn on or off any light switch within the spray area while operating or if fumes are present.
- Do not smoke within the spray area.
- Do not operate a gasoline engine within the spray area.
- If there is any static sparking while using the equipment, **stop spraying immediately**. Identify and correct the problem.



## TOXIC FLUID HAZARD

Hazardous fluid or toxic fumes can cause serious injury or death if splashed in the eyes or on the skin, inhaled, or swallowed.

- Know the specific hazards of the fluid you are using..
- Store hazardous fluid in an approved container. Dispose of hazardous fluid according to all local, state and national guidelines.
- Wear the appropriate protective clothing, gloves, eyewear and respirator.
- Graco does not manufacture or supply any of the reactive chemical components that may be used in this equipment and is not responsible for their effects. Graco assumes no responsibility for loss, damage, expense or claims for personal injury or property damage, direct or consequential, arising from the use of such chemical components.

# WARNING



## EQUIPMENT MISUSE HAZARD

Equipment misuse can cause the equipment to rupture or malfunction and result in serious injury.

- This equipment is for professional use only.
- Read all instruction manuals, tags, and labels before operating the equipment.
- Use the equipment only for its intended purpose. If you are uncertain about usage, call your Graco distributor.
- Do not alter or modify this equipment. Use only genuine Graco parts and accessories.
- Check equipment daily. Repair or replace worn or damaged parts immediately.
- Do not exceed the maximum working pressure of the lowest rated system component. The lever amplification of the secondary pump enables very high fluid pressures to be achieved. To reduce the risk of overpressurizing the equipment, a relief valve is provided on the secondary pump side which is factory set at **1500 psi (10.5 MPa, 105 bar) maximum working pressure**. Do not tamper with this valve adjustment.
- Do not lift pressurized equipment.
- Do not install any fluid shutoff device at the fluid outlet of either heater or filter. Shutting off the fluid at the outlet causes high back pressure.
- Use at least 50 feet (15.2 m) of fluid hose between the fluid outlet and any fluid control device such as a shutoff valve, regulator or spray gun.
- The operating and safety features of this heater are designed to be used only with Graco Foam-Cat® Heated Hoses, Models 218613, 218614, 947514, 947515 and 948723. Never connect other hoses to this heater.
- Do not remove hose spring guards, which help protect the hose from rupture caused by kinks or bends near the couplings.
- Do not use the hose until the couplings are properly insulated and the hose abrasion cover is in place.
- To avoid excessive heat buildup, never operate the hose when it is coiled.
- Route the hoses away from the traffic areas, sharp edges, moving parts, and hot surfaces. Do not expose Graco hoses to temperatures above 180°F (82°C) or below -40°F (-40°C).
- Do not use the hoses to pull the equipment.
- Use fluids and solvents that are compatible with the equipment wetted parts. See the **Technical Data** section of all the equipment manuals. Read the fluid and solvent manufacturer's warnings.
- Do not pressurize a supply drum that will not withstand 5.5 psi (38 kPa, 0.38 bar) working pressure.
- Do not use a damaged drum of ISO or RES with the Air Dryer.
- Comply with all applicable local, state and national fire, electrical and other safety regulations.

# Introduction

## Before you use this equipment

**For your personal safety and optimum equipment performance**, all users of this equipment must thoroughly read and understand all warnings and instructions in each component manual before using this manual, 307541, as a guide for installing and operating a complete Foam-Cat® 400 Sprayer. Each component manual contains “fine tuning” information and pertinent safety information, which is essential for optimum equipment performance.

This manual also contains instructions for installing and using several recommended accessories. If any recommended accessory is not used, just move on to the next section of the manual. If you are using other similar accessories, see the instructions supplied with that equipment.

## Terms

**RES** is the polyurethane foam chemical Resin.

**ISO** is the polyurethane foam chemical, Isocyanate.

**Ambient Temperature** is the surrounding air temperature.

**ATC** is the Ambient Temperature Compensator feature of the Foam-Cat® Heater. See manual 308219 for more information.

**WARNING** alerts the user to avoid or correct conditions that could cause bodily injury.

**CAUTION** alerts the user to avoid or correct conditions that could cause damage to or destroy equipment.

**NOTE** identifies helpful procedures and information.

## If you are using a generator to power your system

See the Foam-Cat Heater manual, 308219, to determine the correct size.

## Component manuals and recommended accessory manuals

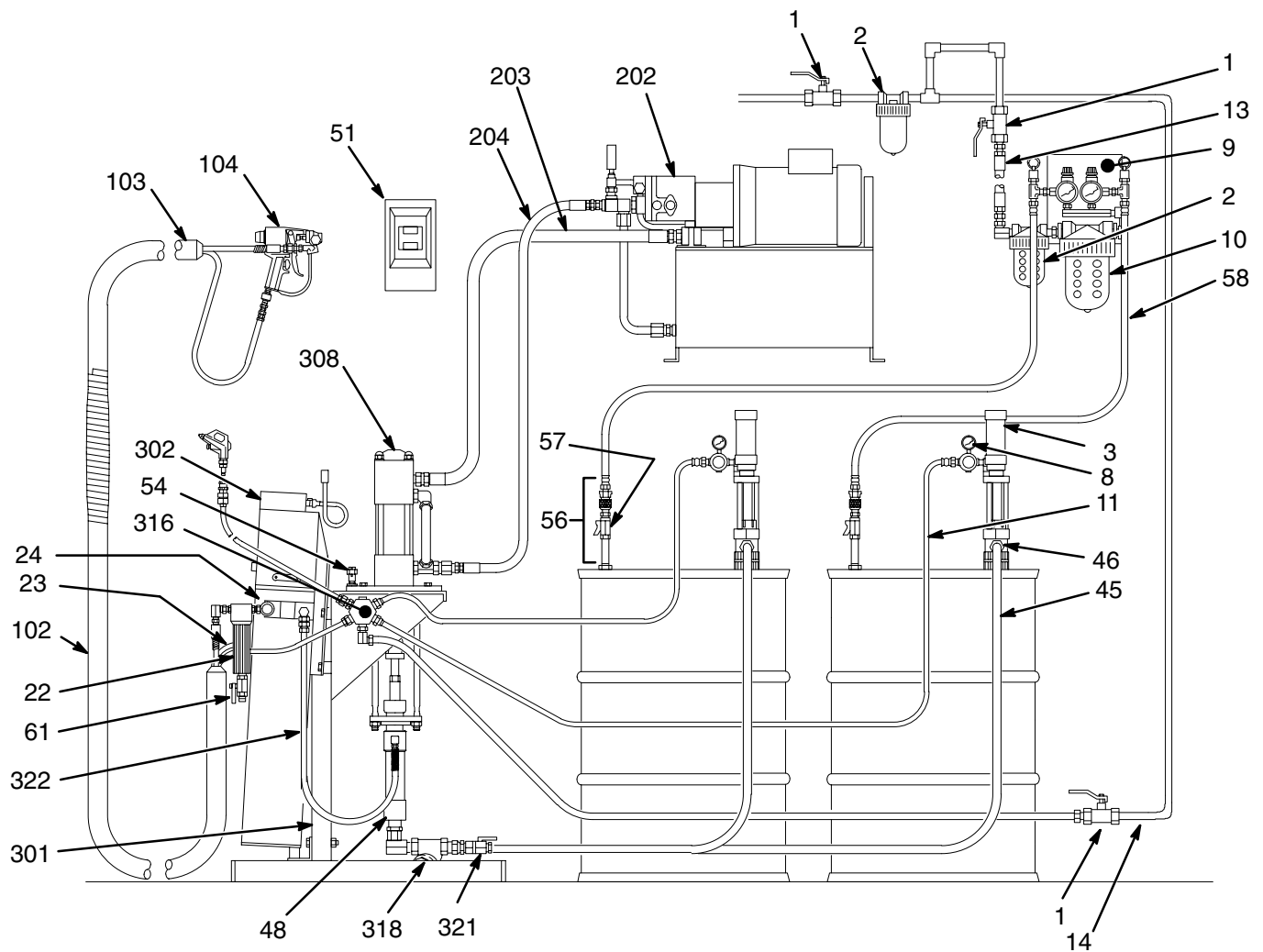
Manual No.	Description
307158	Viscount II Hydraulic Pump Motor <sup>1</sup>
307273	Fluid Filter <sup>1</sup>
307430	Displacement Pump <sup>1</sup>
307552	1:1 Ratio Feed Pumps <sup>3</sup>
307551	Pump Stand <sup>1</sup>
307550	Hydraulic Power Supply <sup>2</sup>
307548	Air Dryer <sup>3</sup>
307547	Plural Component Hydraulic Pump <sup>1</sup>
307546	Foam-Cat Gun <sup>1</sup>
307544	Foam-Cat Heated Hose <sup>1</sup>
308167	Regulator <sup>1</sup>
308219	Foam-Cat Heater <sup>1</sup>

<sup>1</sup> Component in Model 226992

<sup>2</sup> Component in Model 226994

<sup>3</sup> Accessory component, order separately.

# Installation



## KEY

1 Master Air Valve	22 Fluid Filter	56 Drum Fittings, Air Dryer	204 Hydraulic Hose, Supply
2 Air Line Filter	23 Control Box Cable, Heater	57 Shutoff Valve, Drum Fittings	301 Pump Stand
3 Feed Pump	24 Fluid Outlet, Heater	58 Dry Air Hose, Air Dryer	302 Heater
8 Air Regulator Or Air Valve	45 Feed hose, Feed Pump To Disp. Pump	61 Drain Valve, Heater	308 Proportioning Pump
9 Air Dryer	46 Fluid Outlet, Feed Pump	102 Heater Hose	316 Air Manifold
10 Air Dryer Ring	48 Displacement Pump	103 Heated Whip Hose	318 Y-line Strainer
11 Air Hose, Feed Pump Kit	51 Electric Motor Switch	104 Foam-Cat Gun	321 Intake Valve, Disp. Pump
13 Main Air Supply To Dryer	54 Grounding Lug	202 Hydraulic Power Supply	322 Fluid Hose, Disp. Pump To Heater
14 Main Air Supply Hose		203 Hydraulic Hose, Return	

**Fig. 1**

04873

## The Typical Installation

The Typical Installation in Fig. 1 shows all the components and the minimum recommended accessories for a Foam-Cat® Sprayer, Model 226994, and the correct routing of all air and fluid hoses.

## Reference letters and numbers

Parts information for reference numbers 1 to 61 can be found in separate manuals accompanying the sprayer or accessories. These reference numbers do not correspond to those in the separate manuals. Parts information for reference numbers 101 to 339 can be found on pages 20 and 21.

# Installation

**NOTE:** For most steps, if no figure drawing is referenced see Fig. 1 to locate the parts mentioned in the step.

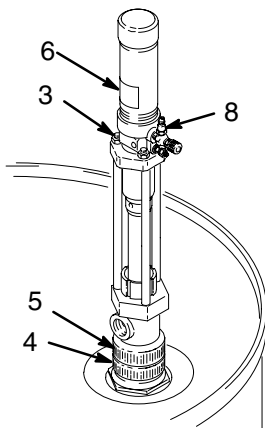
## I. Mount the system.

1. Secure the sprayer stand (301) and the hydraulic power supply (202) to the floor in suitable locations. See the mounting hole diagrams in manuals 307550 and 307551.
2. Install a bleed-type master air shutoff valve (1), Part No. 113218, on the main air supply line to provide a remote shutoff point for all air-powered components, and a main line air filter (2), part no. 106148, 3/8" npt **or** part no. 106149, 1/2", to remove harmful dirt and moisture from the compressed air supply.
3. When operating the proportioning pump at the higher pressure ranges, replace the Y-strainer (318) with a higher capacity Y-Strainer, Part No. 101078. The replacement filter is Part No. 180199.

**NOTE:** The air to the spray gun must be very clean and dry to avoid contaminating the foam.

### **CAUTION**

To avoid mixing the polyurethane foam chemicals and permanently damaging the hoses, all critical air and fluid connections are clearly labeled ISO or RES. Make only ISO to ISO and RES to RES connections.



04438

4. Install the 1:1 ratio feed pumps (3) in 55 gallon drums of ISO and RES. Order Part No. 226946 for the pumps, **or** part no. 217381 for the Feed Pump Kit which includes an Air Dryer (106493), two 1:1 Fast-Flo Pumps (226946), two feed hoses, three air hoses, and the related fittings. Manual 307552 contains installation and operation information.
  - a. Screw the bung adapter (4) and pump tightly into the drum cover. Then tighten the nut (5) firmly to complete the airtight seal. See Fig. 2.

- b. Separate the ISO/RES identification label (6) along the perforation. Clean the surface of the air motor with solvent and apply the appropriate label (RES or ISO) to identify the chemical being pumped. See Fig. 2.
- c. We recommend installing an air regulator near the feed pump air inlet to control pump speed. Remove the air valve (8). Install the regulator and pin fitting using suitable adapters and thread sealant on the male threads. Order Part No. 206199 for an air regulator and gauge.

### **WARNING**

#### **COMPONENT RUPTURE HAZARD**

To reduce the risk of a container rupture and serious injury:

- Never pressurize a drum or container that will not withstand 5.5 psi (0.38 bar) working pressure.
- Never use a damaged drum of ISO or RES with the Air Dryer.

5. Mount the Air Dryer (9) in a suitable location near the ISO and RES drums. Order Part No. 217341, if you did not order the Feed Pump Kit mentioned in Step 4. See the mounting hole diagram in manual 307548.
  - a. Fill the bowl of the desiccant dryer. Unscrew the ring (10) to remove the dryer bowl.
  - b. Remove the filter from the top of the bowl and fill the bowl with the desiccant crystals provided with the kit. Reinstall the filter and bowl.
6. Connect the hydraulic hoses (203 & 204) between the proportioning pump hydraulic motor (308) and the power supply (202).
7. Fill the hydraulic reservoir (A) with 10 gallons (38 liters) of hydraulic oil (206), supplied. Fill the hydraulic pump case (B) with hydraulic oil. See Fig. 3.

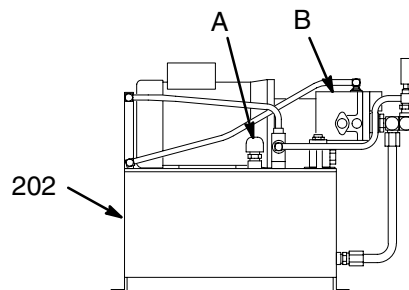


Fig. 3

04874

# Installation

## II . Connect the air hoses.

1. Connect an air supply hose (11) from the 1/4 npt quick disconnect coupler of each feed pump to the air manifold (316).
2. Connect an air supply hose (13) between the air inlet of the Air Dryer and the main air supply line.
3. Connect a grounded 1/2 in. minimum ID main air supply line (14) to the air manifold (316).
4. Be sure all air hose connections are tight.

## III . Connect the heated hose assembly.

1. For heated hose warning and assembly instructions, see manual 307554.
2. Connect the fluid hoses to the corresponding 3/8 npt outlet union of the fluid filters (22). See Fig. 3.
3. Connect the heat tape connector (16) to the hose control box cable (23). See Fig. 3.

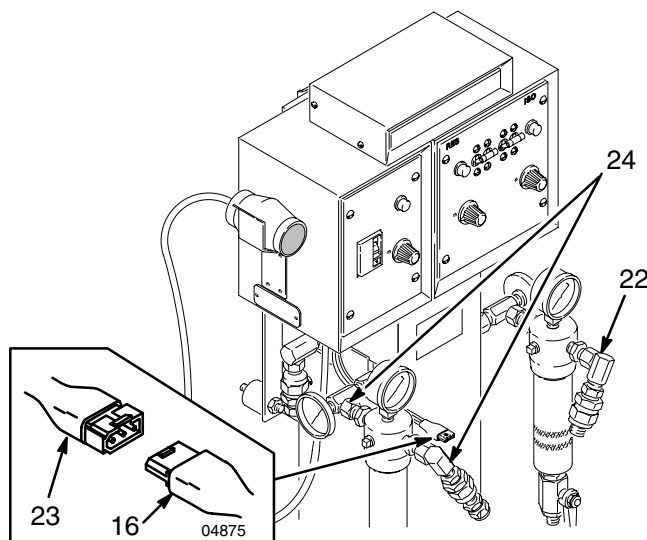


Fig. 4

01294

### KEY

- 30 Nozzle retainer
- 31 Nozzle
- 32 Packing nut
- 33 Packing
- 34 Needle
- 36 Pin vise
- 37 Cleaning pin

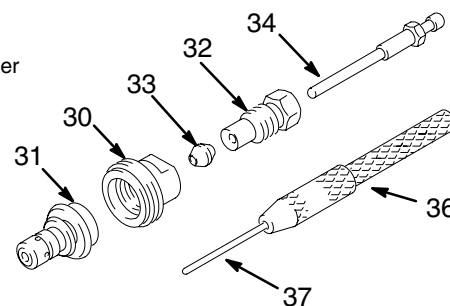


Fig. 5

04442

## ⚠ WARNING

### COMPONENT RUPTURE HAZARD

To reduce the risk of overpressurizing the heater and pump, which can result in serious injury and equipment damage, follow these precautions:

- Do not install any fluid shutoff device as the fluid outlet of either heater or filter! See Ref 24, Fig. 4.
- Use at least 50 ft. (15.2 m) of fluid hose between the fluid outlet and any fluid control device such as a shutoff valve, regulator or spray gun.

## IV . Install a needle/nozzle kit on the gun.

**NOTE:** This kit includes the parts shown in Fig. 5, except the pin vise (36) which holds the cleaning pin (37), and the nozzle retainer (30) which is part of the gun. The wrenches mentioned in the following instructions are provided with the gun.

1. Use the 3/16" wrench (25) to remove one cap-screw (26) from the fluid manifold (27) and two capscrews (26) from the nozzle housing (28). See Fig. 6.
2. Trigger the gun, and then pull the nozzle housing (28) straight off the gun body (29). See Fig. 6.

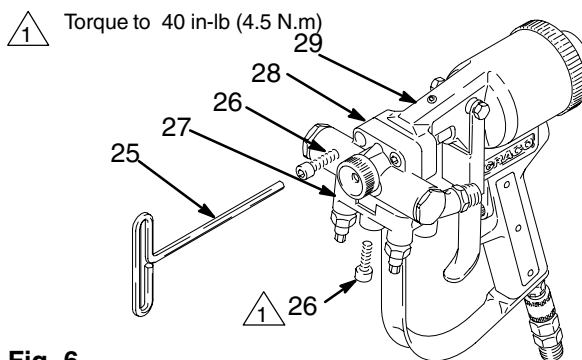


Fig. 6

04443

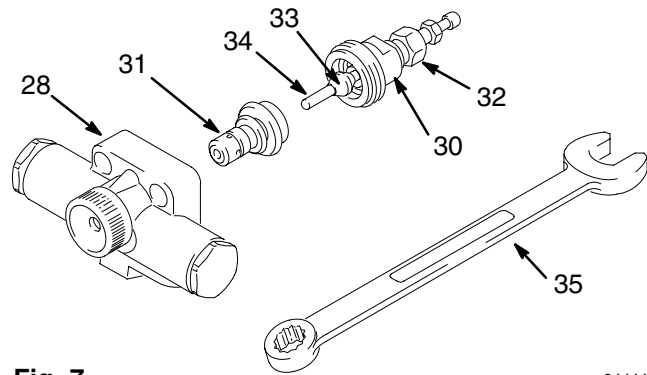
3. Use the 1/2" end of wrench (35) to remove the nozzle retainer (30) from the back of the nozzle housing (28). See Fig. 7.
4. Insert the nozzle (31), tapered end first, into the back of the housing. See Fig. 7.
5. Slide the packing nut (32), nozzle retainer (30), and packing (33) onto the needle (34). Screw the packing nut (32) into the nozzle retainer (30) until the top thread of the packing nut is flush with the back of the retainer. See Fig. 8.
6. Slide the needle assembly through the nozzle and into the nozzle housing assembly. See Fig. 7.
7. Adjust the needle so it protrudes 1–3/4 in. (44 mm) from the rear of the housing. See Fig. 9.

# Installation

- Screw the nozzle retainer (30) snugly into the back of the housing (28). Torque to 25–35 in-lb (2.8–3.9 N.m) using the 1/2" end of wrench (35). See Fig. 9.

## CAUTION

Do not overtighten the nozzle retainer (30). This can compact the nozzle (31) and damage it, or cause it to seat improperly, resulting in spray pattern distortion.



**Fig. 7** 04444

- Top thread of packing nut (32) must be flush with back of retainer (30).

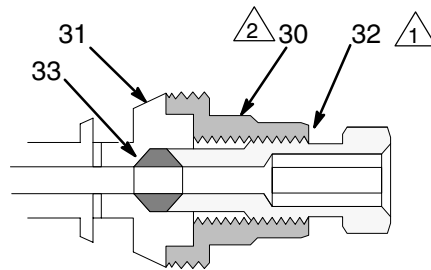
- Guide the needle of the nozzle assembly into the front opening (38) of the gun body (29). The socket of the piston rod (39) must face down. Tilt the nozzle assembly up and swing the ball of the needle (34) into the piston rod socket. See Fig. 10.
- Push the nozzle assembly further into the front opening (38) until the back of the assembly meets the gun body. See Fig. 10.
- Use the 3/16" wrench (25) to install the two top capscrews (26) firmly into the nozzle housing. Torque to 40 in-lb (4.5 N.m). See Fig. 6, page 9.

## WARNING



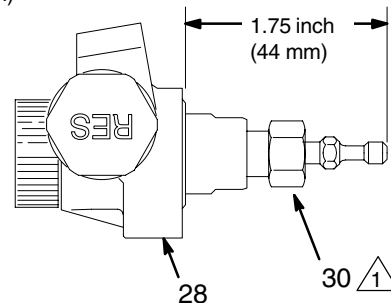
### INJECTION HAZARD

To reduce the risk of serious injury from injection, be sure the trigger safety (40) is locked before proceeding. See Fig. 12.

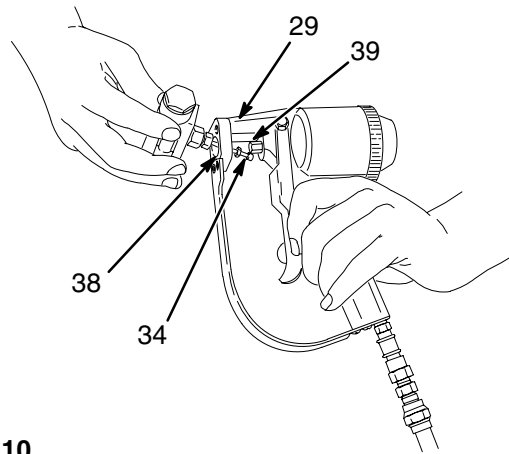


**Fig. 8** 04445

- Torque to 25–35 in-lb (2.8–3.9 N.m)



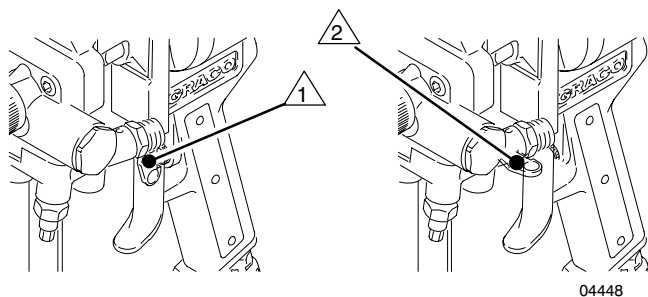
**Fig. 9** 04446



**Fig. 10** 04447

# Installation

- 1 Unlocked trigger safety.
- 2 Locked trigger safety.



04448

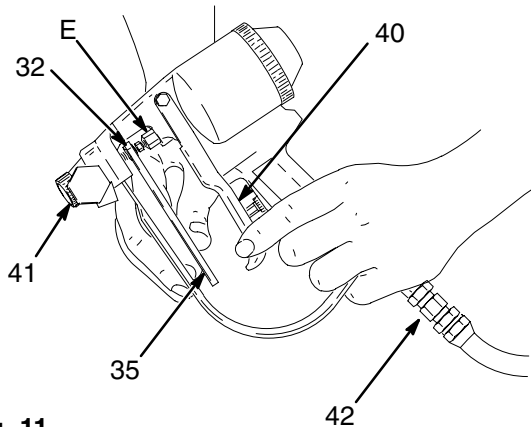


Fig. 11

04449

12. Screw on the air cap (41). Connect the air hose of the heated hose assembly to the inlet bushing (42) of the gun. See Fig. 11.
13. Use the 7/16" end of wrench (35) to adjust the packing nut (32) until it is *just snug*. Don't overtighten it! See Fig. 11.
14. Install the plastic shield (43) around the exposed part of the needle assembly (E) to keep foam overspray from collecting on the needle. See Fig. 11.

## V. Connect the fluid hoses to the spray gun manifold.

1. The gun manifold (27) has four inlet ports; two ports are plugged with steel plugs (44). Relocate the plugs to route the hoses straight down from the manifold, if desired. See Fig. 12.
2. Connect the fluid hoses to the corresponding inlets of the gun manifold.
3. Do not connect the manifold to the gun yet.

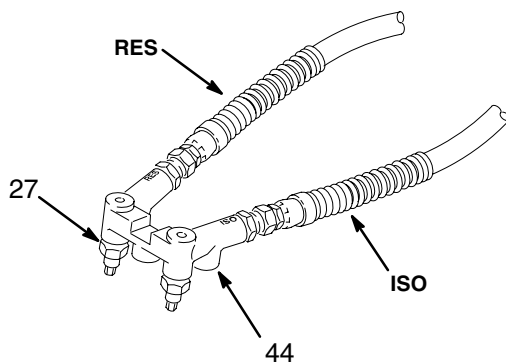


Fig. 12

04877

## VI. Connect the feed hose to the displacement pumps.

1. Slide an identification band (ISO or RES) over the end of each feed hose (45).
2. Connect a feed hose between the feed pump fluid outlet (36) and the 3/4 npt(f) fluid intake valve (321) of each displacement pump (48). See Fig. 1, on page 7.

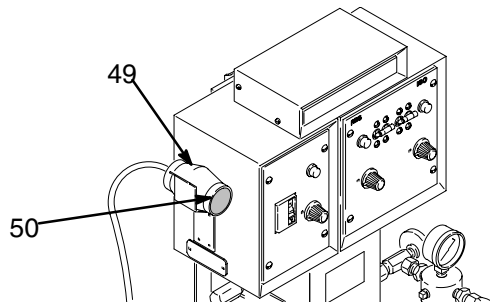


Fig. 13

01294

## VII. Position the ATC Sensor.

1. Remove the **ATC Sensor (49)** from the clamp (50).
2. Locate the sensor *outside* in air that is typical of the surface to be sprayed. The sensor has a 15 ft. (4.6 m) cable. See Fig. 13.

# Installation

## VIII . Wire and electrically ground the system.

**⚠ WARNING**

**FIRE, EXPLOSION AND ELECTRIC SHOCK HAZARD**

To reduce the risk of static sparking, which can cause a fire or explosion and result in serious injury, including electric shock, and property damage, always follow these precautions.

- Read and follow the warnings in **FIRE, EXPLOSION AND ELECTRIC SHOCK HAZARD** on page 4.

- Provide electrical grounding continuity throughout the entire spray system.
- Have a trained and qualified person perform all electrical wiring.
- Comply with all applicable local, state and national fire, electrical and other safety regulations.

1. Wire the power supply cord of the hydraulic supply (202) motor to the electric motor switch (51), supplied. Then wire the electrical service to the switch. See manual 307550.
2. Wire the electrical service to the heater junction box. The electrical requirements for the heater are shown on the inside cover to the heater junction box.

**NOTE:** The heater is grounded through the electrical wiring to a grounding screw on the inside bottom of the junction box. The proportioning pump must also be grounded to provide adequate system electrical grounding.

3. Electrically ground the **proportioning pumps and the feed pumps**. A ground wire and clamp (222011) is provided with both pumps. The grounding lug for the proportioning pump is located on top of the pump stand. The grounding lug for the feed pumps is located at the base of the motor.
  - a. Loosen the grounding lug locknut (55) and washer (52). Insert one end the ground wire (53) into the slot in the lug (54) and tighten the locknut securely. See Fig. 14.
  - b. Connect the other end of the wire to a good ground such as a steel building column (check your local code).

4. Electrically ground the **heater and heated hoses**.

- a. Wire the heater to a positively grounded power supply. In a mobile installation, be sure the truck or trailer is connected to a true earth ground.
- b. Connect the heated hose to a properly grounded heater. The Ground Fault Interrupter on the hose control panel of the Foam-Cat Heater senses electrical continuity in the heated hoses; it cannot function unless the heater is positively grounded. In Europe, the hose continuity must comply with VDE 0100.

5. Use only electrically conductive **air hoses**.

6. Use only Foam-Cat® **Heated (fluid) Hoses**, Models 218613, 218614, which are electrically conductive.

**NOTE:** To ensure positive grounding and further reduce the risk of electric shock, redundant grounding is recommended. The long lines of the shielded-wire heated hose have a higher than normal capacitive leakage current to ground.

7. Obtain electrical grounding for the **spray gun** by connecting it to a properly grounded fluid hose and pump.
8. Electrically ground the following objects according to your local code.

- The **object being sprayed**.
- The **fluid supply container**.
- **All solvent pails** used when flushing. Use only metal pails, which are conductive. Do not place the pail on a non-conductive surface, such as paper or cardboard, which interrupts the grounding continuity.

9. **To maintain grounding continuity when flushing or relieving pressure**, always hold a metal part of the gun firmly to the side of a grounded metal pail, then trigger the gun.

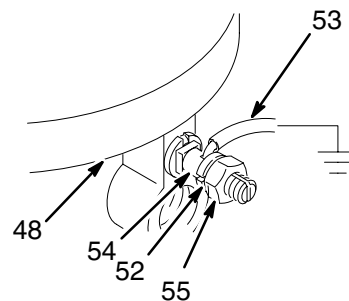


Fig. 14

0720

# Installation

## IX . Install the air dryer drum fittings.

1. Install the drum fittings (56) in the 3/4 in. vent port of the corresponding drum of fluid.
2. Close the shutoff valve (57) and connect the corresponding dry air hoses (58). Use only the special pin fitting (59) and coupler (60) to connect the dry air hoses to the drum fittings. Do not use additional lengths of dry air hose. See Fig. 15.

### **! WARNING**

#### **COMPONENT RUPTURE HAZARD**

The special air line pin fitting (59) and coupler (60) are designed to prevent accidentally coupling an unregulated air supply hose to the drum. Unregulated air can over pressurize the drum and cause it to rupture and cause serious injury.

Do not substitute a different type of coupler and fitting! Use genuine Graco replacement parts.

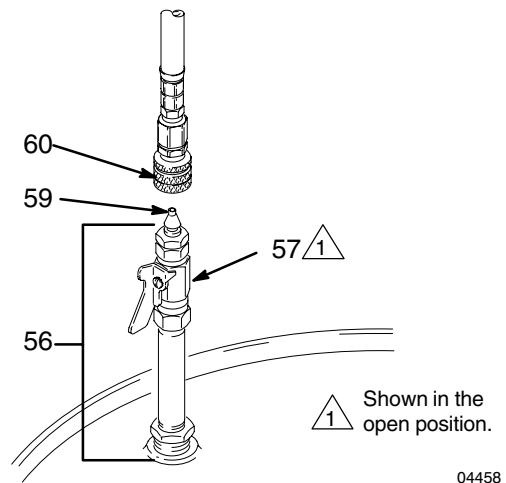
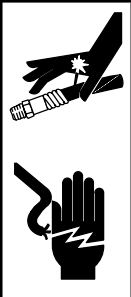


Fig. 15

04458

# Operation - First Time Startup

## Pressure Relief Procedure

<b>⚠ WARNING</b>	
	<b>INJECTION AND ELECTRIC SHOCK HAZARDS</b> To reduce the risk of a serious injury from fluid injection or electric shock, always relieve the fluid pressure in the sprayer and hoses and shut off the electric power before checking or adjusting the hoses or any other component.

1. Lock the spray gun trigger safety.
2. Shut off the air to the feed pumps.
3. Turn off the electric motor switch.
4. Close the gun manifold needle valves.
5. Unlock the trigger safety, trigger the gun to relieve pressure, and lock the trigger safety again.
6. If possible, allow the heater to cool before opening the drain valves. This prevents the resin from frothing.
7. Open both fluid filter drain valves, having a container ready to catch the draining fluid.
8. If you are working on any part of the heater, shut off the main electrical power to the heater.

### I. Prime the hydraulic system.

**NOTE:** For each step, if no figure drawing is referred to, see Fig. 1, on page 7, to locate the parts mentioned in the step.

1. Open the valve (321) at the intake of *each* displacement cylinder of the proportioning pump (308). *Do not* supply RES or ISO to the cylinders yet.
2. Place a waste container under the drain valve (61) of each heater filter (22) to catch the test fluid left in the heater and proportioning pump. Then open both drain valves.
3. Adjust the hydraulic power supply (202) to its **minimum** pressure setting by turning the knob (62) **counterclockwise** until the force from the spring is relieved. See Fig. 16.

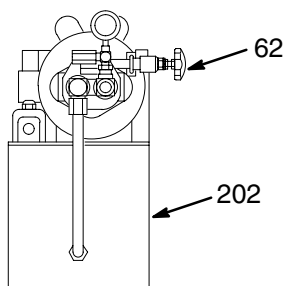


Fig. 16

04878

## ⚠ CAUTION

Do not remove the knob (62) from the pump housing to avoid leaking oil and misaligning the screw.

4. Check the rotation of the hydraulic pump on the reservoir. An arrow on the pump indicates the correct rotation direction. Turn the electric motor switch (51) on and off; if the pump rotates in the wrong direction, have a qualified person change the wiring. See manual 307550.
5. Turn the electric motor switch (51) on and off several times to prime the hydraulic power supply pump.
6. Fill the displacement pump packing nut 2/3 full with IPO (ISO Pump Oil), supplied.
7. Run the proportioning pump at 10 to 20 cycles per minute for two minutes to purge air from the hydraulic system. See **Prime the sprayer** on page 15.

**NOTE:** The speed of the proportioning pump is controlled by adjusting the pressure at the hydraulic pump. Referring to Fig. 16, adjust the pressure by turning the knob (62) *clockwise to increase and counterclockwise to decrease*.

## ⚠ CAUTION

Do not exceed 800 psi (56 bar) hydraulic power supply pump pressure, or a maximum proportioning pump flow rate of 30 lb/min (13.5 kg/min). Excessive hydraulic pressure will cause the power supply motor to draw too much amperage and be damaged.

8. Check the hydraulic oil level (A) to make sure it is in the safe zone on the dipstick. See Fig. 17. Add more hydraulic oil, if needed.

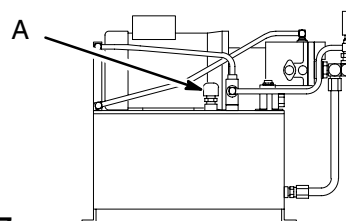



Fig. 17

04874

# Operation - First Time Startup

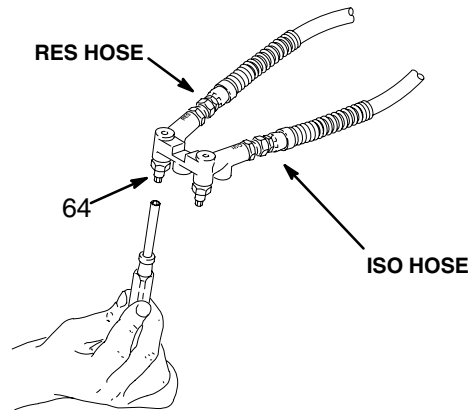
## II . Prime the sprayer.

<b>⚠ WARNING</b>	
	<b>ELECTRIC SHOCK HAZARD</b> Be sure the heater and heated hose circuit breakers (63) are shut off to reduce the risk of electric shock. See Fig. 22, page 18.

**NOTE:** For each step, if no figure drawing is referred to, see Fig. 1, on page 7, to locate the parts mentioned in the step.

1. Close the feed pump air inlet valves or regulators (8).
2. Close the heater drain valves (61).
3. Close the needle valves (64) of the spray gun manifold. See Fig. 18.

<b>⚠ CAUTION</b>
Do not overtighten the needle valves to avoid cracking the seals.



**Fig. 18**

04879

4. Fill the displacement pump packing nut 2/3 full with IPO (ISO Pump Oil), supplied.
5. Be sure the proportioning pump fluid intake valves (321) are open.
6. Open both main air line shutoff valves (1).

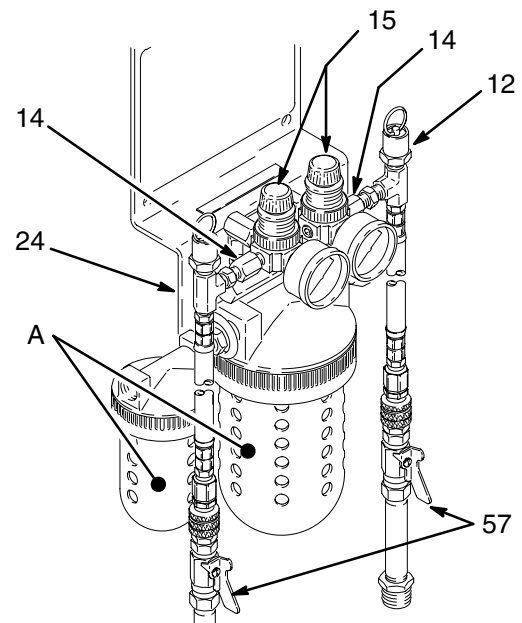
## **⚠ WARNING**

### **COMPONENT RUPTURE HAZARD**

To reduce the risk of overpressurizing the supply drum or container, which could rupture the drum and cause serious injury and property damage follow these precautions.

- Do not operate the Air Dryer with any part removed.
- Do not operate with the restrictor nipple (14) removed. These nipples limit the volume of air to the Air Dryer.
- Do not operate with either pressure relief valves (12) removed. These valves relieve air pressure to the drums if it exceeds 5.5 psi (0.38 bar).
- Do not operate with the metal power guard (A) removed from the oil filter or desiccant dryer.

## III . Adjust the air dryer.



**Fig. 19**

04459

1. Set both air regulators (15) to the lowest pressure needed to provide adequate dry air to the supply drums. A setting of 2 psi (0.14 bar) normally provides enough dry air to the drums. See Fig. 19.
2. Open the drum shutoff valves (57). See Fig. 19.
3. To lower the pressure on the gauge, turn the regulator knob counterclockwise and pull up on the pressure relief valve ring (12) until the pressure on the gauge is just below the desired setpoint. Release the ring and then turn the knob to the desired pressure. See Fig. 19.

# Operation - First Time Startup

## **! WARNING**

### **COMPONENT RUPTURE HAZARD**

If either pressure relief valve (12) is not operating properly, or if the drum pressure ever exceeds 5.5 psi (0.38 bar), replace the valve immediately. A malfunctioning relief valve can allow the drum to over pressurize and rupture, resulting in serious injury and property damage. Therefore, *never* attempt to repair the valve.

4. Check the pressure relief valves daily. To check, close the drum shutoff valves (57) and uncouple the air hoses (58) from the pin fitting. Increase the air pressure slowly. If pressure is not relieved by 5.5 psi (0.38 bar), replace the valve. See Fig. 19.

**NOTE:** A minimum pressure of 1 psi (0.07 bar) is needed to open the check valves (14).

### **IV . Prime the hoses.**

1. Open the feed pump air valves (8).
2. Turn on the electric motor switch.
3. With the gun disconnected from the manifold, hold the manifold (27) so each outlet port is directly over a separate waste container as shown in Fig. 20.

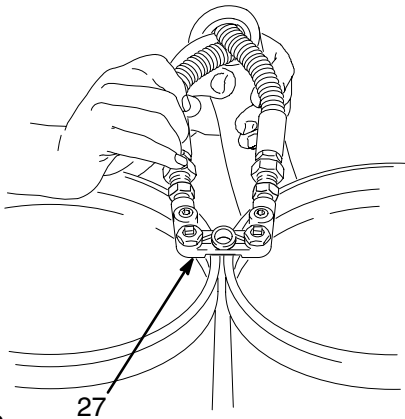


Fig. 20

04452

4. Open the manifold needle valves (64). See Fig. 18, page 15. Allow the material to flow out until all air is purged from the sprayer and the spitting stops.
5. Close the needle valves. Do not connect the manifold and the gun.
6. Throw away the purged material in both waste containers to avoid contaminating your supply containers with test fluid left in the components after factory testing.

### **V . Check each fluid connection for leaking.**

## **! WARNING**



### **INJECTION AND ELECTRIC SHOCK HAZARDS**

To reduce the risk of a serious injury from fluid injection or electric shock, always follow the **Pressure Relief Procedure** on page 14 before checking or adjusting the hoses or any other component.



If there are any leaks, relieve the fluid pressure and tighten the connection.

# Operation - General Startup Instructions

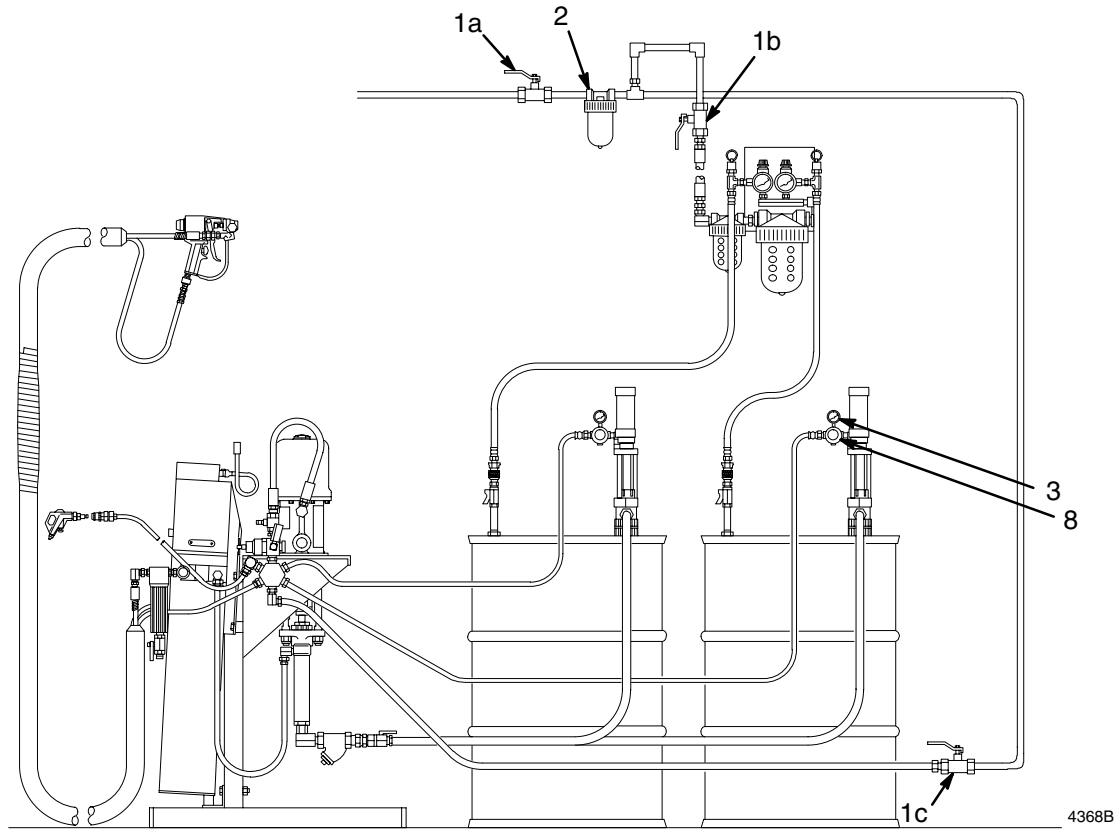
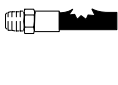


Fig. 21

<b>⚠ WARNING</b>	
	<p><b>COMPONENT RUPTURE HAZARD</b> Never operate the hose when it is coiled. Doing so causes excessive heat buildup which can result in hose rupture and cause serious injury, including injection and property damage. The high heat can also cause poor foam development.</p>

<b>⚠ CAUTION</b>	
<p>The heater and sprayer must be primed before turning on the heater to reduce the risk of equipment damage.</p> <p>See Operation - First Time Startup on pages 14 through 16 for the priming procedure.</p>	

**NOTE:** The first time you operate the sprayer follow these instructions carefully. Then, as you become familiar with this equipment, you will learn how to quickly adjust the fluid pressure and the fluid temperature to obtain the best results for your spray application.

**NOTE:** For each step, if no figure drawing is referred to, see Fig. 21.

## I. Start the sprayer.

1. Check the oil level in the hydraulic power supply (202) reservoir. Add more oil, if needed.
2. Open the main air supply valve and the air valves (8) to the feed pumps (3).
3. Turn on the electric motor switch (51) to the hydraulic power supply and adjust the fluid outlet pressure of the proportioning pump (308) to 700 psi (49 bar).

<b>⚠ CAUTION</b>	
<p>To prevent the motor from drawing too much amperage, which can cause equipment damage, follow these precautions.</p> <ul style="list-style-type: none"> <li>• Do not exceed 800 psi (56 bar) hydraulic pump pressure.</li> <li>• Do not use a spray nozzle rated at over 30 lb/min (13.5 kg/min)</li> </ul>	

4. Start the heaters. See Fig. 22.
  - a. Set all three Temp Set dials (73) to “cal” position, approximately 120°F (49°C).
  - b. Turn the circuit breakers (63) to “I” for ON.
  - c. Let the material heat for 15 minutes.

# Operation - General Startup Instructions

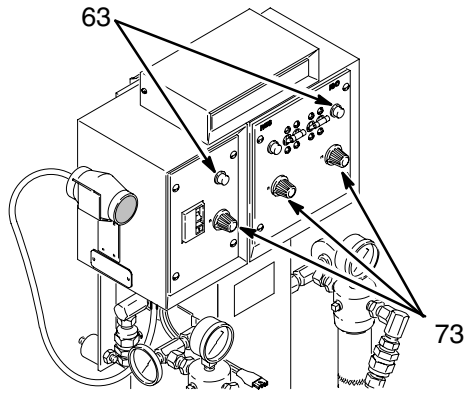


Fig. 22

04880

## CAUTION

Open the RES side needle valve first to prevent damage to the nozzle.

- Test the spray pattern. Aim the gun at a piece of scrap cardboard and trigger for 1 second to check the spray pattern. A good pattern should be round and well atomized, and it should harden with a fairly smooth surface. See the **Nozzle performance Chart** for the proper size of pattern and spray distance for the nozzle being used.

**NOTE:** Release the gun trigger at least once a minute, while spraying, if you use a no-release triggering method. This is to actuate the mechanical purger and avoid material buildup on the nozzle tip and air cap.

- Spray the gun for several seconds, in cold weather, to warm the fluid nozzle.

### NOZZLE PERFORMANCE CHART

Nozzle Kit No.	Needle Diameter In. (mm)	DELIVERY		
		Outlet Pressure psi (bar)	Flow Rate <sup>1</sup> lb/min (kg/min)	Pattern Diameter <sup>2</sup> In. (mm)
<sup>3</sup> 217421	0.114 (2.90)	1200 (154) 950 (6) 750 (53)	41 (18.4) 35 (15.8) 29 (13.1)	18 (457)
217423	0.089 (2.26)	1000 (70) 750 (53)	19 (8.6) 15 (6.6)	17 (432)
217424	0.073 (1.85)	1000 (70) 750 (53)	10.5 (4.7) 8.5 (3.8)	12 (305)
217425	0.083 (2.11)	1000 (70) 750 (53)	15 (6.6) 12 (5.5)	17 (432)
217426	0.102 (2.59)	1200 (154) 950 (6) 750 (53)	19 (13.1) 25 (11.3) 21.5 (9.7)	17 (432)


<sup>1</sup> Flow rate test conditions: 2.7 lb (1.22 kg) foam; ISO viscosity of 200 CPS (200 MPa-s) at 77°F (25°C); RES viscosity of 650 CPS (650 MPa-s) at 68°F (20°C); heater and hose temperature of 115°F (43°C); pump outlet pressure as indicated in chart.

<sup>2</sup> At the recommended 30 in. (762 mm) spraying distance.

<sup>3</sup> We do not recommend using Nozzle Kit 217421 with the Foam-Cat 400 Sprayer at pressures higher than 950 psi (66 bar).

# Operation - General Startup Instructions

7. Adjust the gun's clean-off air.

<b>⚠ WARNING</b>	
	<b>INJECTION HAZARD</b> To reduce the risk of an injection injury, always follow the items in Step 7 carefully before adjusting the clean-off air.

- a. Lock the trigger safety (40).
- b. Close the needle valves (64).
- c. Unlock the trigger safety.
- d. Trigger the gun to relieve the fluid pressure.
- e. Lock the trigger safety again. See Fig. 23.
- f. Using a hex key wrench (71), screw in the set-screw (72) of the clean-out hole until no air or almost no air is escaping. See Fig. 23.
- g. Regulate the air to the gun to 100 psi (7 bar).
- h. Back off the setscrew two turns as a test setting.
- i. If the air appears to affect the spray pattern, screw in the setscrew another turn. If build up behind the air cap occurs, back off the set-screw about 1/2 turn at a time.

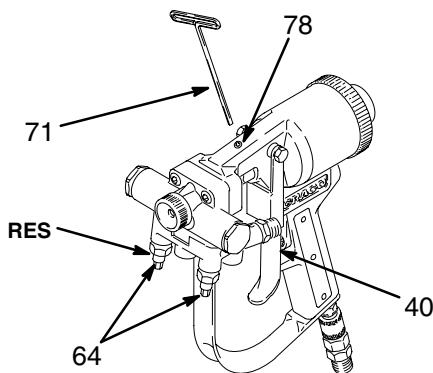



Fig. 23

04457

## II. Shutdown

<b>⚠ WARNING</b>	
	<b>INJECTION AND ELECTRIC SHOCK HAZARDS</b> To reduce the risk of a serious injury from fluid injection or electric shock, always follow the <b>Pressure Relief Procedure</b> on page 14 before checking or adjusting the hoses or any other component.

At the end of each work day, stop the pump with the displacement rod in the *down* position. Shut off the heat and main circuit breakers and relieve the fluid pressure. Disconnect the gun from the fluid manifold, flush the gun as instructed in manual 307546, and store the gun.

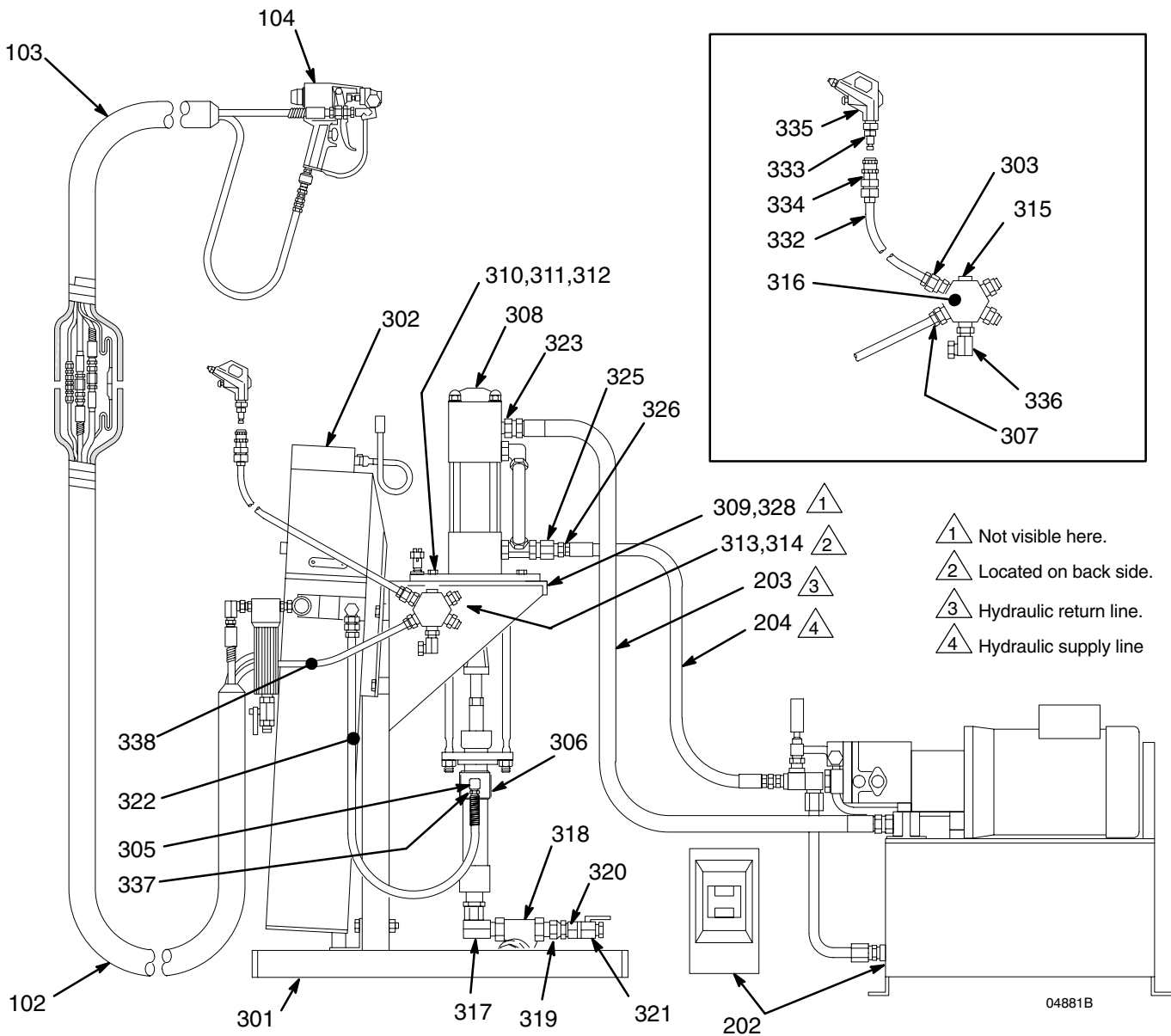
## III. Maintenance

Keep the displacement pump packing nut 2/3 full of IPO at all times to help protect the pump packings.

<b>⚠ CAUTION</b>
Trace amounts of IPO may get into the foam. Before using the IPO make sure that it will not affect the development and appearance of the foam.

See the separate instruction manual for each system component for routine maintenance and repair procedures.

# Parts



## Model 226992, Foam-Cat® 400

Without a hydraulic power supply  
Includes items 101 to 105 and 301 to 339

Ref No.	Part No.	Description	Qty
101	226989	FOAM SPRAYER (see items 301 to 339)	1
102	218613	HOSE, heated (see 307544 for parts)	1
103	218614	HOSE, heated, whip (see 307544 for parts)	1
104	217373	GUN, foam	1
105	217421*	KIT, nozzle, gun, 0.114" dia. (not shown, see 307546 for parts and other available sizes)	1

## Model 226994, Foam-Cat® 400

With a hydraulic power supply  
Includes items 101 to 105, 201 to 206 and 301 to 339.

Ref No.	Part No.	Description	Qty
201	226992	FOAM-CAT 400 SPRAYER (Includes items 101 to 105 at the left)	1
202	106522	HYDRAULIC POWER SUPPLY (see 307550 for parts)	1
203	155816	HOSE, hydraulic, 6 ft (1.9 m) 3/4" ID, coupled 3/4 npt(mbe)	1
204	158743	HOSE, hydraulic, 6 ft (1.9 m) 1/2" ID, coupled 3/8 npt(mbe)	1
205	158586	BUSHING, 3/4 npt(f) x 1" npt(m)	1
206	169236*	OIL, hydraulic, 5 gal (19 liter)	1

# Parts

## Model 226989, Series B Basic Foam-Cat System

Includes items 301 to 339

Ref No.	Part No.	Description	Qty	Ref No.	Part No.	Description	Qty
301	217-296	STAND, pump (see 307551 for parts)	1	320	157785	UNION, straight, 3/4 npsm(f) swivel x 3/4 npt(m)	2
302	235260	HEATER, 30 lb/min (13.5 kg/min)	1	321	108537	BALL VALVE, 3/4 npt(fbe)	2
303	162449	NIPPLE, reducing, 1/2 to 1/4 npt	1	322	217378	HOSE, cpld 3/8 npt(mbe), 3/8" ID, spring guard one end, 2.5 ft (780 mm)	2
305	155699	ELBOW, street, 90°, 3/8 npt (mxf)	2	323	202965	UNION, adapter, 3/4 npsm(f) swivel x 1" npt(m)	1
306	178600	LABEL, ISO/RES	1	325	112574	UNION, swivel, 3/4" npt(f)	1
307	155571	BUSHING, pipe, 1/2 npt(m) x 1/4 npt(f)	1	326	102281	BUSHING, pipe, 3/4 npt(f) to 3/8 npt(f)	1
308	217337	PUMP, foam, hydraulic (See manuals 307158, 307547 and 307430 for parts)	1	328	102556	RIVET, blind	2
309	150707	LABEL, serial	1	330✓	217374	OIL, pump, ISO, 1 pt (0.46 liter)	1
310	100003	CAPSCREW, hex head, 3/8 npt x 1.5" (32 mm)	4	332	212005	HOSE, air, 1/4" ID, cpld 1/4 npsm(f) swivel, 3'9" (1.1 m)	1
311	100133	LOCKWASHER, spring, 3/8"	4	333	100030	BUSHING, hex, 1/4 x 1/8 npt	2
312	100131	NUT, hex, 3/8 npt	4	334	106552	COUPLING, air line, quick disconnect	1
313	100333	CAPSCREW, hex head, 1/4 thread x 0.5" (13 mm)	2	335	208625	GUN, air blow	1
314	100016	LOCKWASHER, spring, 1/4"	2	336	155470	UNION, swivel 90°, 1/2 npt(m) x 1/2 npsm swivel	1
315	100737	PLUG, pipe, 1/2 npt	3	337	100081	BUSHING, pipe, 1/2 npt to 3/8 npt	2
316	177117	MANIFOLD, air, six 1/2 npt(f) ports	1	338	200118	HOSE	1
317	160327	ADAPTER, union, 90°, 3/4 npt(m) x 3/4 npt(f) swivel	2	339	218669	KIT, solvent	1
318	101078	STRAINER, "Y", 20 mesh screen, 3/4 npt(fbe), Includes item 318a	2				
318a	180199	.ELEMENT, filter, 20 mesh screen	1				
319	160032	NIPPLE, 3/4 npt x 1-7/8" (47 mm)	2				

✓ Recommended "tool box" spare parts. Keep on hand to reduce down time.

# Graco Standard Warranty

Graco warrants all equipment manufactured by Graco and bearing its name to be free from defects in material and workmanship on the date of sale by an authorized Graco distributor to the original purchaser for use. With the exception of any special, extended, or limited warranty published by Graco, Graco will, for a period of twelve months from the date of sale, repair or replace any part of the equipment determined by Graco to be defective. This warranty applies only when the equipment is installed, operated and maintained in accordance with Graco's written recommendations.

This warranty does not cover, and Graco shall not be liable for general wear and tear, or any malfunction, damage or wear caused by faulty installation, misapplication, abrasion, corrosion, inadequate or improper maintenance, negligence, accident, tampering, or substitution of non-Graco component parts. Nor shall Graco be liable for malfunction, damage or wear caused by the incompatibility of Graco equipment with structures, accessories, equipment or materials not supplied by Graco, or the improper design, manufacture, installation, operation or maintenance of structures, accessories, equipment or materials not supplied by Graco.

This warranty is conditioned upon the prepaid return of the equipment claimed to be defective to an authorized Graco distributor for verification of the claimed defect. If the claimed defect is verified, Graco will repair or replace free of charge any defective parts. The equipment will be returned to the original purchaser transportation prepaid. If inspection of the equipment does not disclose any defect in material or workmanship, repairs will be made at a reasonable charge, which charges may include the costs of parts, labor, and transportation.

**THIS WARRANTY IS EXCLUSIVE, AND IS IN LIEU OF ANY OTHER WARRANTIES, EXPRESS OR IMPLIED, INCLUDING BUT NOT LIMITED TO WARRANTY OF MERCHANTABILITY OR WARRANTY OF FITNESS FOR A PARTICULAR PURPOSE.**

Graco's sole obligation and buyer's sole remedy for any breach of warranty shall be as set forth above. The buyer agrees that no other remedy (including, but not limited to, incidental or consequential damages for lost profits, lost sales, injury to person or property, or any other incidental or consequential loss) shall be available. Any action for breach of warranty must be brought within two (2) years of the date of sale.

Graco makes no warranty, and disclaims all implied warranties of merchantability and fitness for a particular purpose in connection with accessories, equipment, materials or components sold but not manufactured by Graco. These items sold, but not manufactured by Graco (such as electric motors, switches, hose, etc.), are subject to the warranty, if any, of their manufacturer. Graco will provide purchaser with reasonable assistance in making any claim for breach of these warranties.

In no event will Graco be liable for indirect, incidental, special or consequential damages resulting from Graco supplying equipment hereunder, or the furnishing, performance, or use of any products or other goods sold hereto, whether due to a breach of contract, breach of warranty, the negligence of Graco, or otherwise.

## **FOR GRACO CANADA CUSTOMERS**

The parties acknowledge that they have required that the present document, as well as all documents, notices and legal proceedings entered into, given or instituted pursuant hereto or relating directly or indirectly hereto, be drawn up in English. Les parties reconnaissent avoir convenu que la rédaction du présente document sera en Anglais, ainsi que tous documents, avis et procédures judiciaires exécutés, donnés ou intentés à la suite de ou en rapport, directement ou indirectement, avec les procédures concernées.

## Graco Information

**TO PLACE AN ORDER**, contact your Graco distributor, or call one of the following numbers to identify the distributor closest to you:

**1-800-367-4023 Toll Free**

**612-623-6921**

**612-378-3505 Fax**

*All written and visual data contained in this document reflects the latest product information available at the time of publication. Graco reserves the right to make changes at any time without notice.*

**Sales Offices:** Minneapolis, Detroit

**International Offices:** Belgium, Korea, Hong Kong, Japan

**GRACO INC. P.O. BOX 1441 MINNEAPOLIS, MN 55440-1441**

**www.graco.com**

PRINTED IN USA 307541 05/1982, Revised 08/2002