

100% Fully Recirculating Liquid Ring Vacuum Pump

The **Airtech 2BL Series** vacuum pump is an ideal alternative to rotary vane, rotary screw and oil sealed liquid ring technology.

The patented vacuum pump does not require external water and eliminates oil useage, filters and has an exhaust temperature below ambient!

Features:

- Oil Free
- Self-contained 100% recirculating
- Maintenance Free
- Capacities up to 680CFM
- Generates 28.5" Hg (35 Torr)



Model 2BL 1801

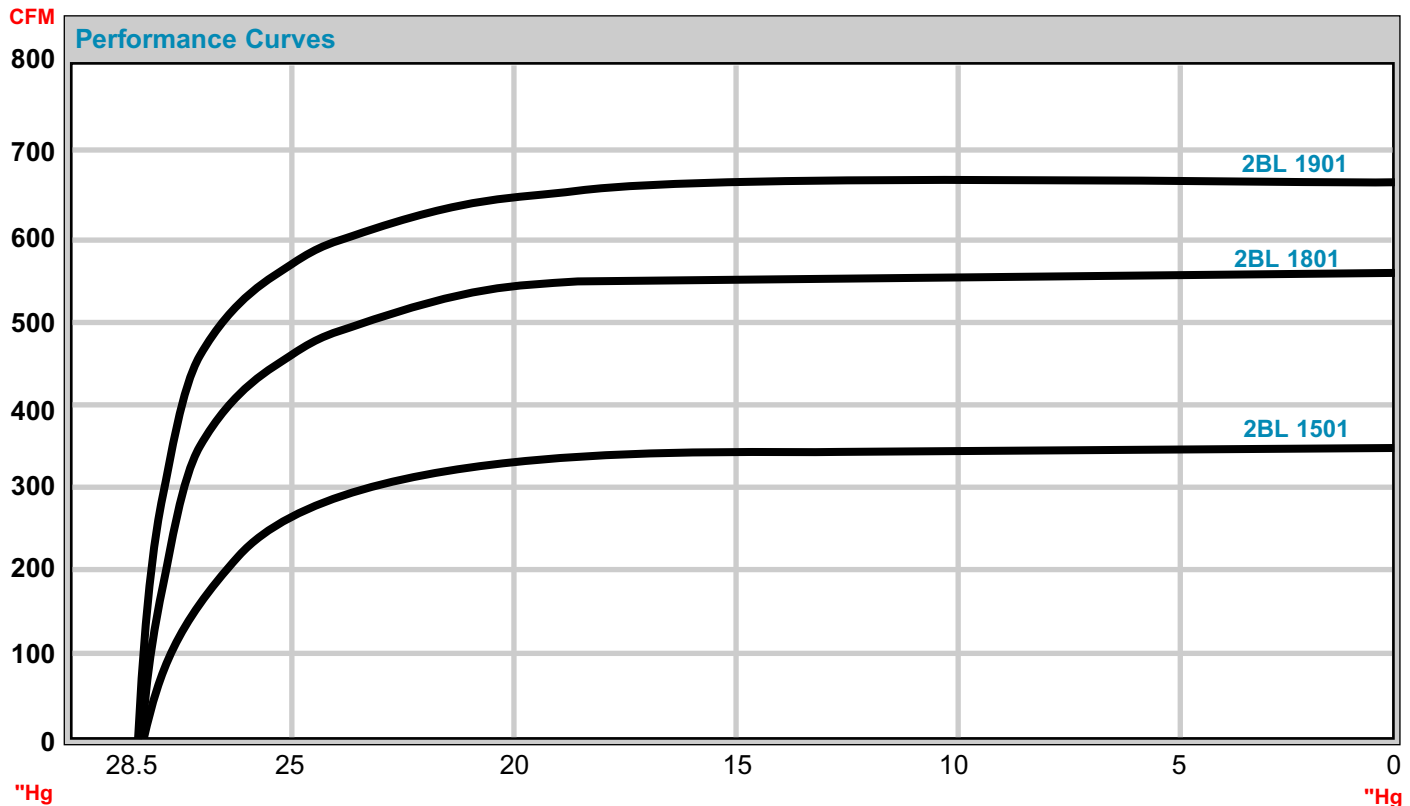

Dimensions: (inches)

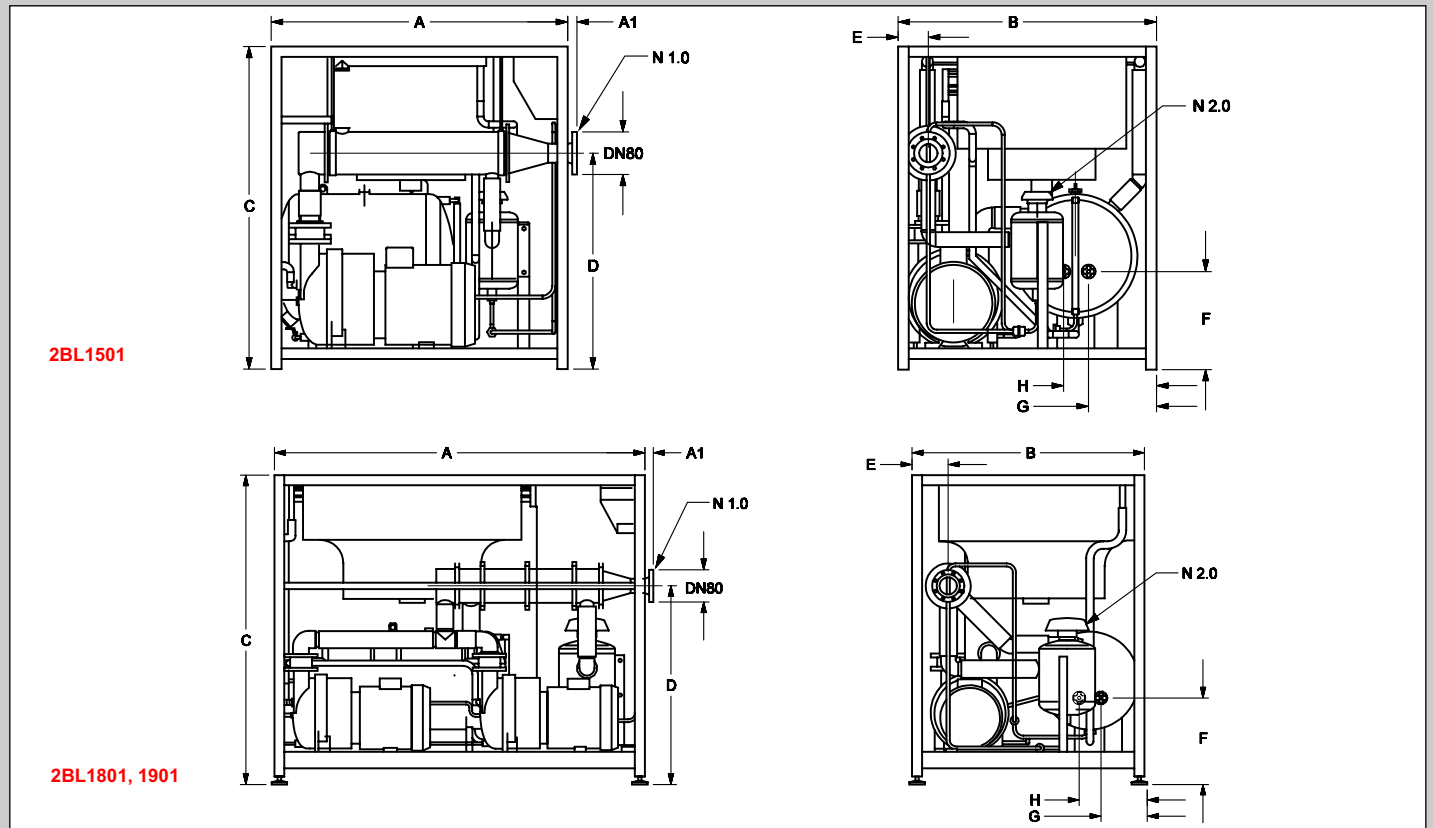

Model #	A	A1	B	C	D	E	F	G	H
2BL1501	58 1/2	2	49 5/8	63	52 13/16	5 15/16	20 5/16	13 1/8	18
2BL1801	86 5/8	2	51 5/8	70 3/4	46 1/8	8 5/16	22	10 5/16	15 5/16
2BL1901	89 7/16	2	55 1/2	74 5/8	50	8 5/16	22	10 5/16	15 5/16

Performance Data - 60 Hz

Model #	Rated H.P.	Nominal CFM	Voltage ³	Rated AMPS	Sound Level dB(A)	Approximate Weight (lbs.)
2BL1501	24	340	220/275-380/480	71/41.5	74	1257
2BL1801	44 ¹	555	220/275-380/480	2x52/32.5	73	1709
2BL1901	48 ²	680	220/275-380/480	2x72/41.5	74	2039

Materials of Construction*:

- Pump casing & Impeller - Cast Iron
- Radiator cooler - Copper tubing
- Condensation cooler - Stainless steel
- Separator - Steel galvanized

* Complete stainless steel available

¹ 1801 utilizes 2 x 22 HP pumps

² 1901 utilizes 2 x 24 HP pumps

³ Voltage tolerance – 10%